

LOC		DIST		REVISIONS			
P	F	ZONE	LTR	DESCRIPTION	DATE	APPD	
AD	39		E	REV PER 0010-1061-94	7-14-94	JH	
			F	REV PER 0010-1175-95	12-30-96	JH	
			G	REV PER 063C-0062-00	11FEB00	MZ	

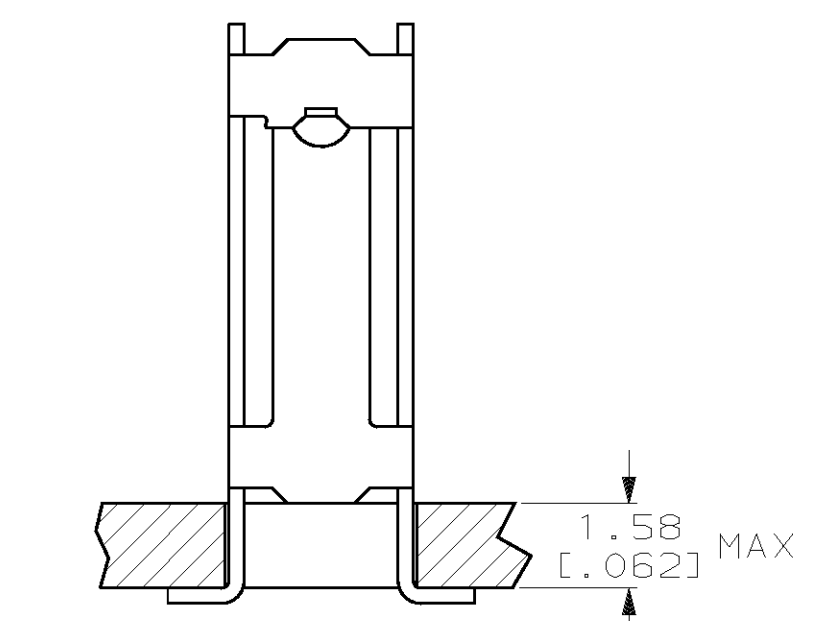

- 1 SHEAR LINES DEFINE LOOSE PIECE PART.
- 2. FOR USE WITH AMPMODU MINATURE APPLICATOR.
- 3 CONTACT MATERIAL: 0.25 [.010] COMERCIAL PHOSPHOR BRONZE.
- 4 GOLD FLASH OVER 0.00127 [.000050] NICKEL ENTIRE CONTACT, 0.00038 [.000015] GOLD ON CONTACT AREA
- 5 "H", (RECEPTACLE CENTERS) MAY VARY DEPENDING ON REQUIREMENTS, MINIMUM NOMINAL CENTER SPACING BETWEEN ADJACENT RECPETACLES IS 3.81 ±0.08 [.150 ±.003].
- 6 0.00200 [.000079] MIN TIN.
- 7 0.00038 [.000015] GOLD IN CONTACT AREA, 0.00254-0.00508 [.000100-.000200] BRIGHT TIN-LEAD IN TERMINATION AREA, ALL OVER 0.00127 [.000050] NICKEL.
- 8 0.00076 [.000030] GOLD IN CONTACT AREA, 0.00254-0.00508 [.000100-.000200] BRIGHT TIN-LEAD IN TERMINATION AREA, ALL OVER 0.00127 [.000050] NICKEL.
- 9 POINT OF MEASUREMENT FOR PLATING THICKNESS.

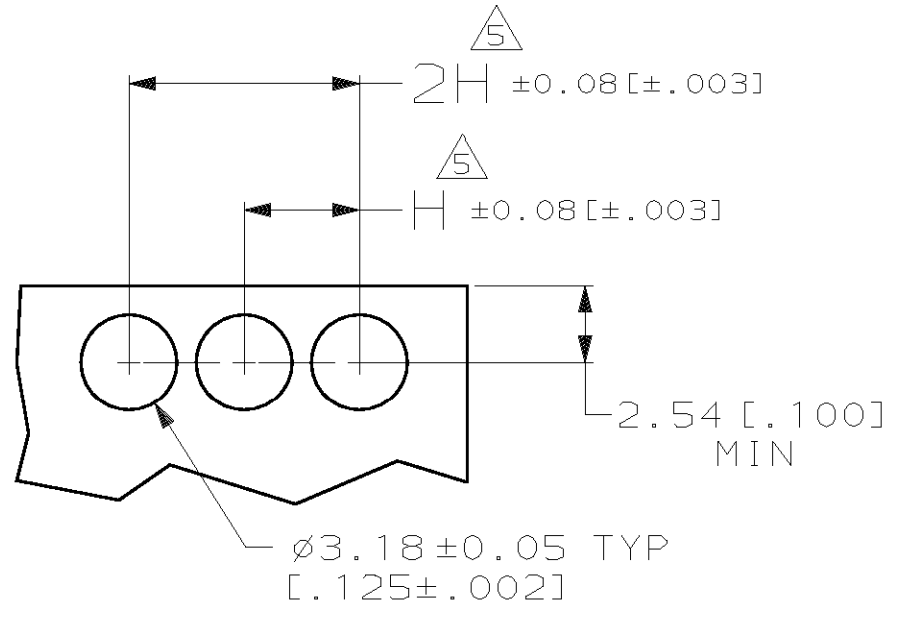
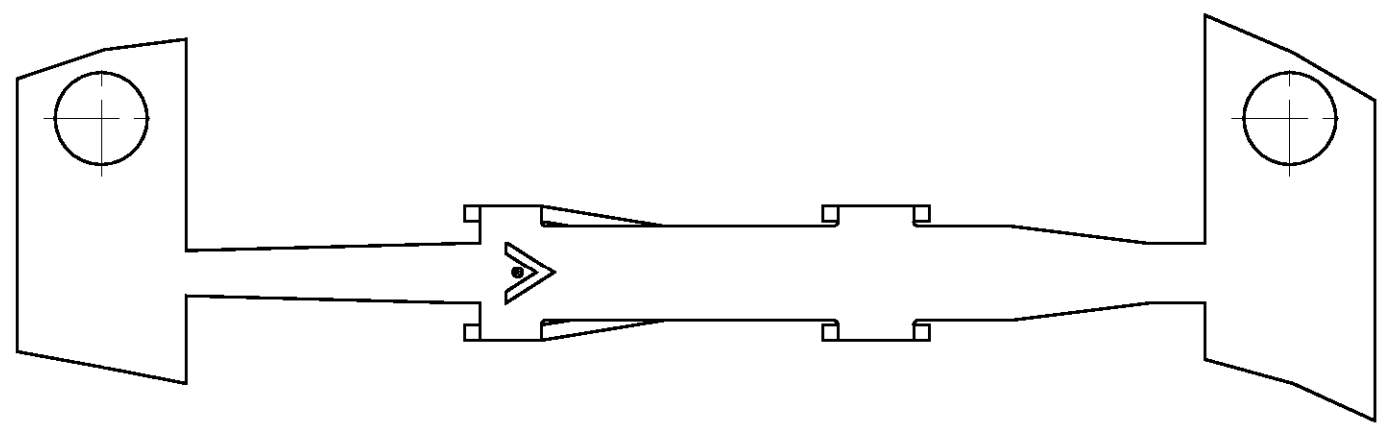
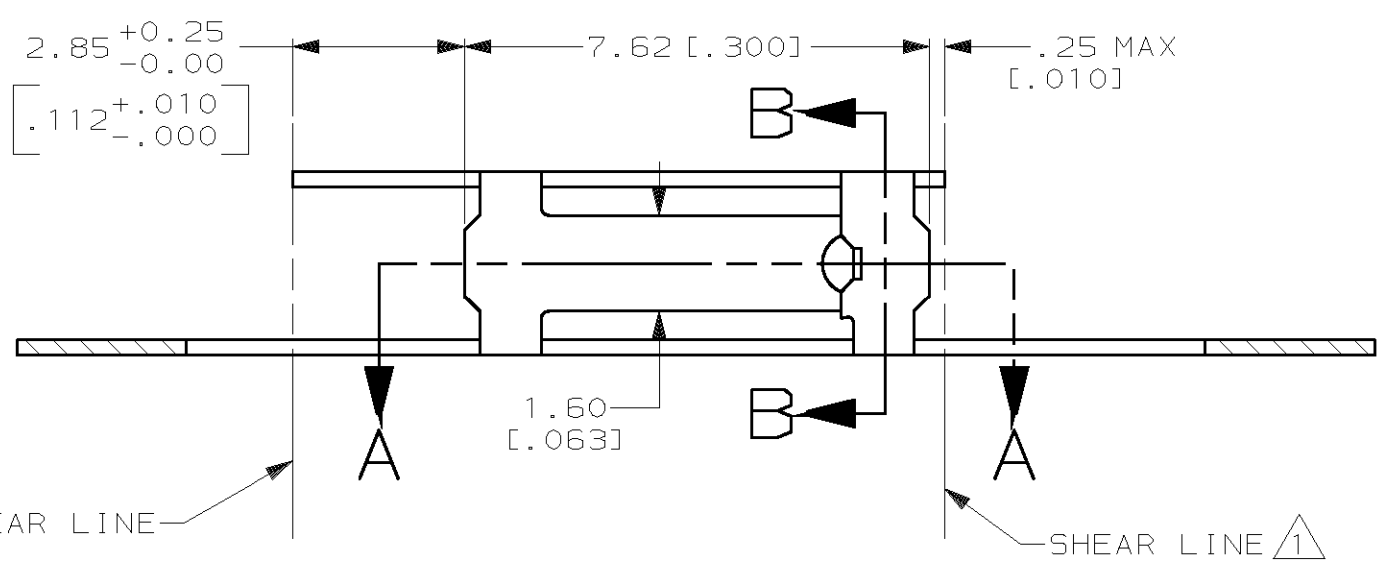
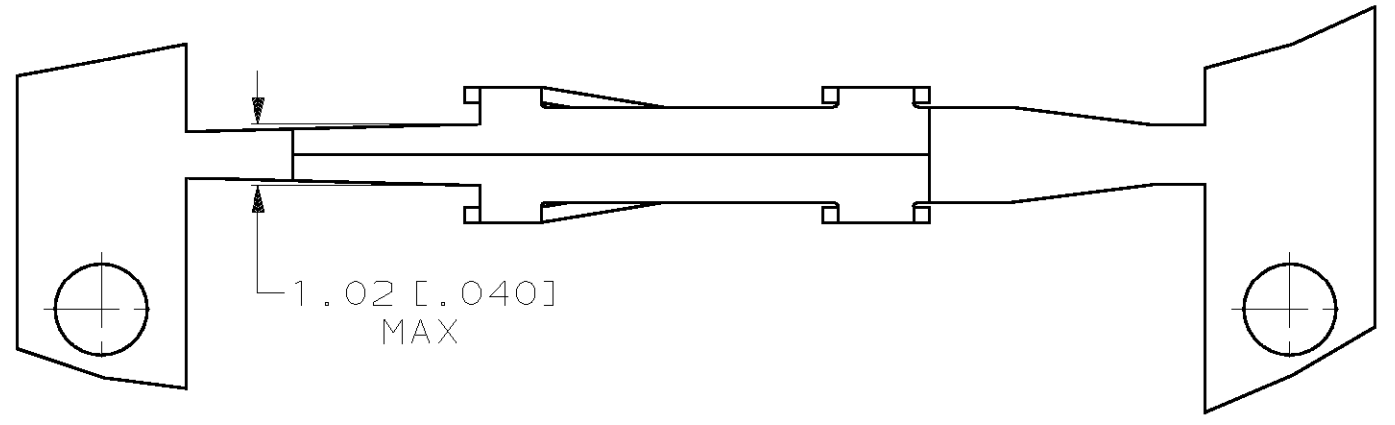
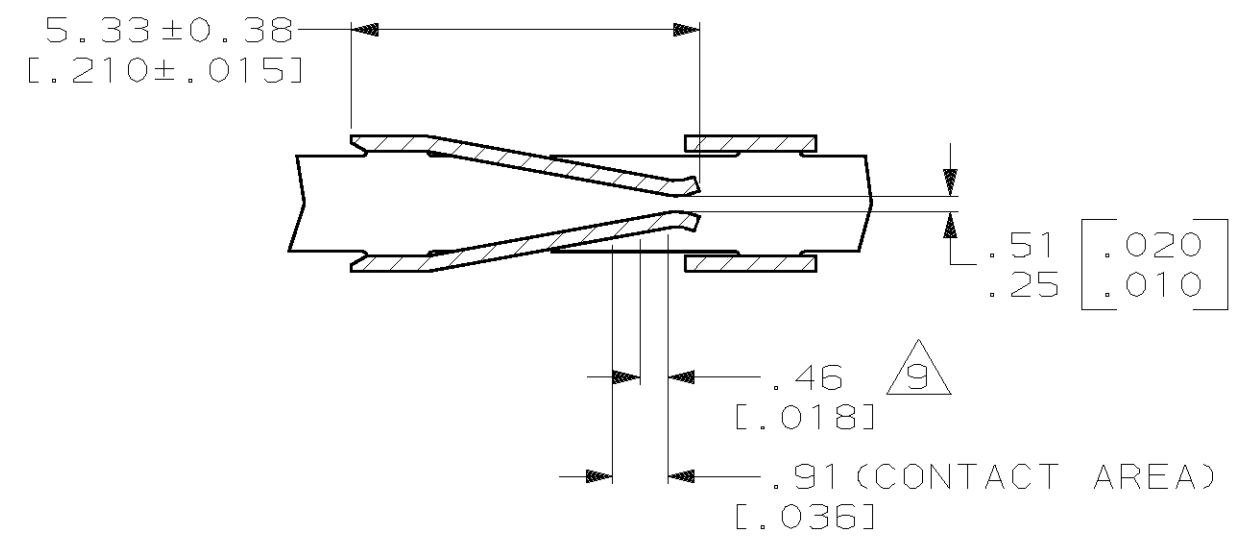
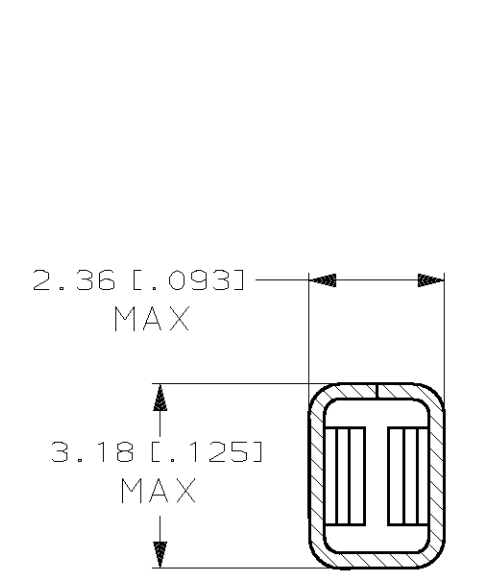

SECTION B-B

SECTION A-A

OBSOLETE	87509-4	8	3	87316-5
OBSOLETE	87509-3	7	3	87316-4
	87509-2	6	3	87316-3
	-	-	-	-
OBSOLETE	87509-1	4	3	87316-1
	LOOSE PIECE PART NO	FINISH	MATERIAL	PART NUMBER

DO NOT SCALE PRINT. UNLESS SPECIFIED DIMENSIONS IN mm [INCHES] TOLERANCES ON:		DR 7-14-94 E. BRANDBERG		AMP AMP Incorporated Harrisburg, PA 17105-3608	
2 PLC DEC ± -		CHK 7-14-94 J. HERRINGTON		NAME	
3 PLC DEC ± 0.13 [.005]		APPD 7-14-94 J. HERRINGTON		FEMALE CONTACT, MOD I, TYPE "A", HIGH PRESSURE	
ANGLES ± -		APPD 7-14-94 D. DUPLER		SIZE	CAGE CODE
MATERIAL	SEE TABLE	PRODUCT SPEC		8	00779
FINISH	SEE TABLE	APPLICATION SPEC		DRAWING NO	C=87316
WEIGHT	-			SCALE	8:1
				SHEET	1 OF 1

THIS DRAWING IS A CONTROLLED DOCUMENT FOR AMP INCORPORATED. IT IS SUBJECT TO CHANGE AND THE CONTROLLING ENGINEERING ORGANIZATION SHOULD BE CONTACTED FOR THE LATEST REVISION.